

# **Feedback and Uncertainty:**

## **Some Basic Problems and Theorems**

**Lei Guo**

Institute of Systems Science, AMSS,  
Chinese Academy of Sciences, Beijing

Hendrik W. Bode Lecture

The 58<sup>th</sup> IEEE CDC, Nice, France, December 13, 2019

# Feedback

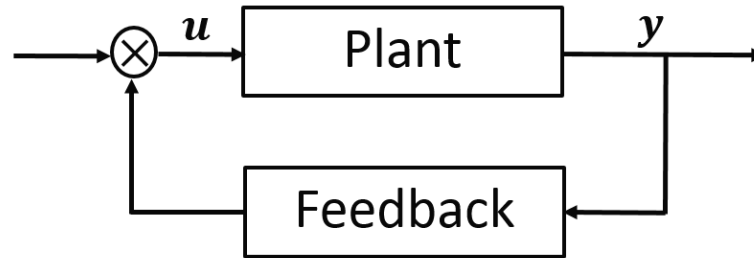

- Feedback is ubiquitous and is a **most basic concept** of automatic control.
- Feedback control has been a **central theme** in control systems, and tremendous progress has been made in both theory and applications.
- One celebrated example is the **Bode's integral formula**[1] on sensitivity functions, which reveals a **fundamental limitation of feedback**, and has had a lasting impact on the field[2].

[1] H.W. Bode, Network Analysis and Feedback Amplifier Design, Van Nostrand, New York, 1945.

[2] J. Chen, S. Fang and H. Ishii, Fundamental limitations and intrinsic limits of feedback: An overview in an information age, Annual Reviews in Control, <https://doi.org/10.1016/j.arcontrol.2019.03.011>

# Uncertainty

- Uncertainty is ubiquitous too, either internal or external.
- Uncertainty necessitates the use of feedback and can be dealt with by feedback effectively .
- Usually described by a set mathematically, either parametric or functional.

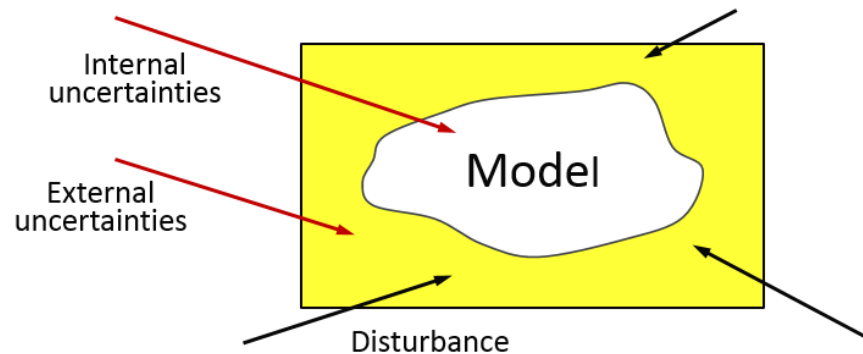

# Feedback and Uncertainty

- The feedback control of **uncertain** dynamical systems is by definition the control of **all possible** systems relating to this uncertainty set, by using available system information.

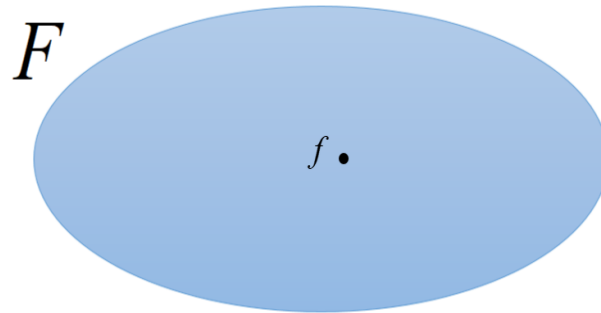

- Modeling, identification and feedforward are also instrumental, but we will focus on **feedback and uncertainty** in this lecture.

# This lecture will talk about

## 1. Self-Tuning Regulator(STR)

(linear systems with nonlinear feedback)

## 2. Classical PID Control

(nonlinear systems with linear feedback)

## 3. Capability of Feedback

(nonlinear systems with nonlinear feedback)

# 1. Why talk about STR?

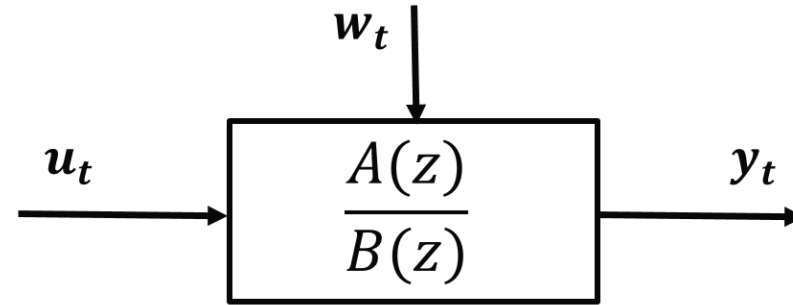

- Basic and natural

- linear systems in discrete-time with random noise;
  - least-squares estimation + minimum variance control.

- Historical role

- A long-standing open problem in theory

- The closed-loop system equation is a complicated nonlinear and nonstationary stochastic process.

- Useful implications

- For more complicated problems where online learning is combined with feedback

- **Historical role of STR**

As pointed out by Lennart Ljung in his preamble[1] to the reprint of the seminal paper “On self-tuning regulators” by Åström and Wittenmark(1973) :

“The paper by Åström and Wittenmark had an immediate impact. Literally thousands of papers on self-tuning regulation, both theoretical and applied, appeared in the next decade. On the theoretical front, the paper **left open the question of convergence and stability** and this inspired much subsequent research.”

[1] Tamer Başar(Ed), Control Theory: Twenty-Five Seminal Papers(1932-1981), pp.423-424, IEEE Press, 2001

“The lasting influence of the paper is perhaps best judged by the fact that today there are many thousands of control loops in practical use that have been designed using the self-tuning concept.”

“The self-tuning regulator revitalized the field of adaptive control that had lost, in the early 1970s, some of its earlier lustre.”

[1] Tamer Başar(Ed), Control Theory: Twenty-Five Seminal Papers(1932-1981), pp.423-424, IEEE Press, 2001



- **A long-standing open problem:**

Stability, convergence and optimality

- Extensive related investigations, e.g.,

R.E. Kalman(1958)

K.J. Åström and B. Wittenmark(1973)

L. Ljung(1976, 1977)

J.B. Moore(1978)

V. Solo(1979)

G.C. Goodwin, P.J. Ramadge, and P.E. Caines(1980,1981)

T.L. Lai and C.Z. Wei (1982, 1986)

A. Becker, P.R. Kumar and C.Z. Wei(1985)

H.F. Chen and L. Guo(1986,1987)

P.R. Kumar(1990)

L. Guo and H.F. Chen(1991)

L. Guo(1995)

.....

## 2. Why talk about PID?

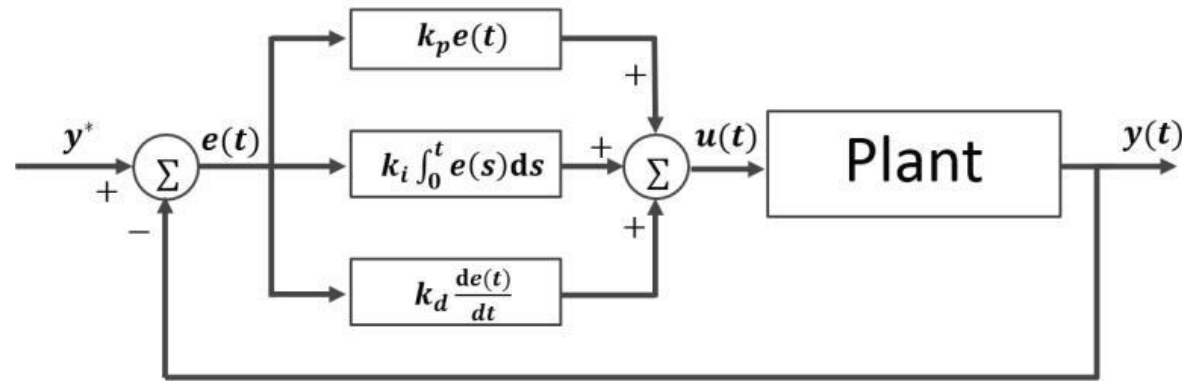

- Linear combination of the “**present-past-future**” output errors.  
**Model-free**, data-driven, simple and easy-to-use.
- Can **eliminate** steady state offsets via the integral action, and can **anticipate** the tendency through the derivative action.
- The **Newton's second law** corresponds to a second order differential equation, which is just suitable for PID control.

# The impact of PID

- Despite the remarkable progresses in modern control theory, the classical PID controller is still the most widely used one in engineering systems, and “we still have nothing that compares with PID” [1].
- For example, more than 95% control loops are of PID type in process control. The PID controller can be said as the “bread and butter” of control engineering [2].
- There are various PID software packages, commercial PID hardware modules, and patented PID tuning rules.

[1] T. Samad, “A survey on industry impact and challenges thereof,” IEEE Control Systems Magazine, vol. 37, no. 1, 2017.

[2] K.J. Åström and T. Hägglund, PID Controllers: Theory, Design and Tuning. Instrument Society of America, 1995.

# A long history with continued investigation

## Some early development

J.Watt(1788)

G.B. Airy(1840)

J.C.Maxwell(1868)

J.Vyshnegradskii(1876)

E.J.Routh(1877)

A.Hurwitz(1895)

E.Sperry(1911)

N.Minorsky(1922)

A. Canllendar et al (1936)

J.G.Ziegler and N.B.Nichols(1942)

.....

## Some recent investigations

K.J. Åström and T. Hägglund ( 1995, 2006)

J. Ackermann and D. Kaesbauer(2001)

Z.P. Jiang and I. Mareels(2001)

W.-D. Chang, R.-C. Hwang and J.-G. Hsieh(2002)

H.K. Khalil (2002)

M.T. Söylemez, N. Munro and H.Baki (2003)

F. Blanchini, A. Lepschy, S. Miani (2004)

S. Hara, T. Iwasaki and D. Shiokata (2006)

N.J. Killingsworth and M. Krstic (2006)

L. Qu, W. Zhang and D. Gu(2006)

G.J. Silva, A. Datta and S.P. Bhattacharyya (2007)

L.H. Keel and S.P. Bhattacharyya(2008)

F. Padula and A. Visioli(2012)

M. Fliess and C. Join (2013)

J.G. Romero, A. Donaire, R. Ortega and B. Boria (2018)

C. Zhao and L. Guo(2017, 2019)

D. Ma and J. Chen( 2018)

J.K. Zhang and L. Guo(2019)

.....

# Further investigation is required

- Most of the theoretical studies on PID focus on linear systems. To justify the remarkable practical effectiveness of the PID controllers, we need to face **nonlinear uncertain** dynamical systems, and to understand **the rationale and capability** of the PID controller.
- On the other hand, a large number of the practical PID loops are believed to be **poorly tuned**[1], and better understanding of the PID control may improve its widespread practice and so contribute to better product quality[2].

[1] A. O'Dwyer, "PI and PID controller tuning rules: an overview and personal perspective," Proc. of the IET Irish Signals and Systems Conference, pp. 161–166, 2006.

[2] K.J. Åström and T. Häggglund, PID Controllers: Theory, Design and Tuning, Instrument Society of America, 1995.

### 3. Why talk about feedback capability?

- Both STR and PID are **special forms** of feedback laws.
- By **feedback capability** we mean the maximum capability and fundamental limitations of the feedback mechanism, defined as the class of **all possible feedback laws**.
- **Our emphasize** will be placed on the relationship between feedback and uncertainty, to understand how much uncertainty can be dealt with by the feedback mechanism.
- We are interested to know not only what the feedback mechanism can do, but also what the feedback mechanism **cannot do**, in the presence of large structural uncertainties.

# Capability and Limitations

Not merely intellectual curiosity.

- **Maximum Capability of Feedback:** Can encourage us in improving the controller design to reach or approach the maximum capability, and may help us in alleviating the workload of modeling and identification.
- **Fundamental Limitations of Feedback:** Can prevent us from wasting time and energy on searching for a feedback controller that does not exist, and alert us of the danger of being unable to control uncertain systems when the size of the uncertainty reaches the limit established.

The most relevant research areas on feedback and uncertainty are **adaptive control** and **robust control**, among others.

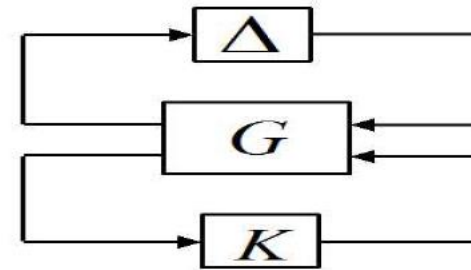
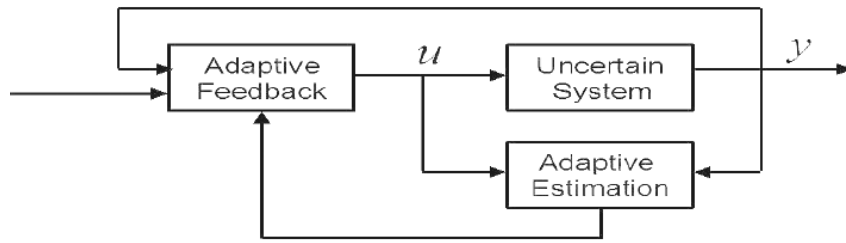

However, only a few results address the **maximum capability** and **fundamental limitations** of the feedback mechanism, see, e.g., [1] and [2] for some uncertain linear systems.

[1] P.E. Caines and H.F. Chen, "On the adaptive control of stochastic systems with random parameters: A counter-example", Ric. Autom., XIII, 190-196, 1982.

[2] P. P. Khargonekar, T. T. Georgiou, and A. M. Pascoal, "On the robust stabilizability of linear time invariant plants with unstructured uncertainty", IEEE-TAC, 32(3), 201-207, 1987



# **1. Self-Tuning Regulators**

# Linear Stochastic Systems

For simplicity, consider the SISO case with additive noise,

$$y_{k+1} + a_1 y_k + \cdots + a_p y_{k-p+1} = b_1 u_k + \cdots + b_q u_{k-q+1} + w_{k+1}, \quad k \geq 0,$$

where  $u_k$ ,  $y_k$  and  $w_k$  are the system input, output and random noises, respectively. The coefficients  $a_i$  and  $b_j$  are assumed to be unknown.

Linear regression form

$$y_{k+1} = \boldsymbol{\theta}^T \boldsymbol{\varphi}_k + w_{k+1}, \quad k \geq 0,$$

where the regression vector and parameter vector are defined by

$$\begin{aligned} \boldsymbol{\varphi}_k &= [y_k, \dots, y_{k-p+1}, u_k, \dots, u_{k-q+1}]^T, \\ \boldsymbol{\theta} &= [-a_1, \dots, -a_p, b_1, \dots, b_q]^T. \end{aligned}$$

# Basic Assumptions

**A1.** The noise  $\{w_k, \mathcal{F}_k\}$  is a martingale difference sequence, and there exists a constant  $\beta > 2$  such that

$$\sup_{k \geq 0} \mathbb{E}[|w_{k+1}|^\beta | \mathcal{F}_k] < \infty, \quad a.s.$$

**A2.** The system is minimum phase.

**A3.** The reference sequence  $\{y_k^*\}$  is bounded and independent of  $\{w_k\}$ .

## Optimal Non-adaptive Control

Consider the optimal tracking problem

$$J_k = \min_{u_k \in \mathcal{F}_k} E(y_{k+1} - y_{k+1}^*)^2, \quad k \geq 1.$$

At any time  $k$ , the best prediction to  $y_{k+1}$  is  $\mathbb{E}[y_{k+1} | \mathcal{F}_k] = \varphi_k^T \theta$ .  
When  $\theta$  is known, the **optimal control** can be solved by setting

$$\mathbb{E}[y_{k+1} | \mathcal{F}_k] = y_{k+1}^*$$

to get an explicit expression

$$u_k = \frac{1}{b_1} (a_1 y_k + \cdots + a_p y_{k-p+1} - b_2 u_{k-1} - \cdots - b_q u_{k-q+1} + y_{k+1}^*).$$

with the following optimal cost:

$$J_k = \mathbb{E}[w_{k+1}^2 | \mathcal{F}_k], \quad \forall k \geq 1.$$

## Least Squares (LS)

$$\boldsymbol{\theta}_k = \arg \min_{\boldsymbol{\theta} \in \mathbb{R}^{p+q}} \sum_{j=1}^k (y_j - \boldsymbol{\varphi}_{j-1}^T \boldsymbol{\theta})^2, \quad \forall k \geq 1,$$

which can be solved explicitly

$$\boldsymbol{\theta}_k = \left( \sum_{j=1}^k \boldsymbol{\varphi}_{j-1} \boldsymbol{\varphi}_{j-1}^T \right)^{-1} \left( \sum_{j=1}^k \boldsymbol{\varphi}_{j-1} y_j \right),$$

and calculated recursively by

$$\boldsymbol{\theta}_{k+1} = \boldsymbol{\theta}_k + a_k P_k \boldsymbol{\varphi}_k (y_{k+1} - \boldsymbol{\varphi}_k^T \boldsymbol{\theta}_k),$$

$$P_{k+1} = P_k - a_k P_k \boldsymbol{\varphi}_k \boldsymbol{\varphi}_k^T P_k, \quad a_k = (1 + \boldsymbol{\varphi}_k^T P_k \boldsymbol{\varphi}_k)^{-1},$$

where the initial estimate  $\boldsymbol{\theta}_0 \in \mathbb{R}^{p+q}$ , and the initial positive definite matrix  $P_0 \in \mathbb{R}^{(p+q) \times (p+q)}$  can be chosen arbitrarily.

# Self-Tuning Regulator (STR)

Using the online LS, one can construct an **adaptive predictor**  $\hat{y}_{k+1}$  based on the "certainty equivalence principle", i.e.,

$$\hat{y}_{k+1} = \varphi_k^T \theta_k.$$

Now, let  $\hat{y}_{k+1} = y_{k+1}^*$ , the STR can be expressed as follows:

$$u_k = \frac{1}{b_{1k}} (a_{1k}y_k + \cdots + a_{pk}y_{k-p+1} - b_{2k}u_{k-1} - \cdots - b_{qk}u_{k-q+1} + y_{k+1}^*),$$

where  $a_{ik}, b_{ik}$  are the components of the LS estimate  $\theta_k$ .

To avoid possible zero divisor problem,  $b_{1k}$  can be modified slightly and replaced by

$$\hat{b}_{1k} = \begin{cases} b_{1k}, & \text{if } |b_{1k}| \geq \frac{1}{\sqrt{\log r_{k-1}}} \\ b_{1k} + \frac{\text{sign}(b_{1k})}{\sqrt{\log r_{k-1}}}, & \text{otherwise} \end{cases}$$

where  $\text{sign}(\cdot)$  is the sign function, and  $r_k$  is defined by

$$r_k = e + \sum_{i=0}^k \|\varphi_i\|^2, \quad k \geq 1.$$

## The Closed-Loop System

$$y_{k+1} + a_1 y_k + \cdots + a_p y_{k-p+1} = b_1 u_k + \cdots + b_q u_{k-q+1} + w_{k+1}, k \geq 0.$$

$$\boldsymbol{\theta}_{k+1} = \boldsymbol{\theta}_k + a_k P_k \boldsymbol{\varphi}_k (y_{k+1} - \boldsymbol{\varphi}_k^T \boldsymbol{\theta}_k),$$

$$P_{k+1} = P_k - a_k P_k \boldsymbol{\varphi}_k \boldsymbol{\varphi}_k^T P_k, \quad a_k = (1 + \boldsymbol{\varphi}_k^T P_k \boldsymbol{\varphi}_k)^{-1}.$$

$$\boldsymbol{\theta}_k = [-a_{1k}, \dots, -a_{pk}, b_{1k}, \dots, b_{qk}]^T$$

$$u_k = \frac{1}{\hat{b}_{1k}} (a_{1k} y_k + \cdots + a_{pk} y_{k-p+1} - b_{2k} u_{k-1} - \cdots - b_{qk} u_{k-q+1} + y_{k+1}^*).$$

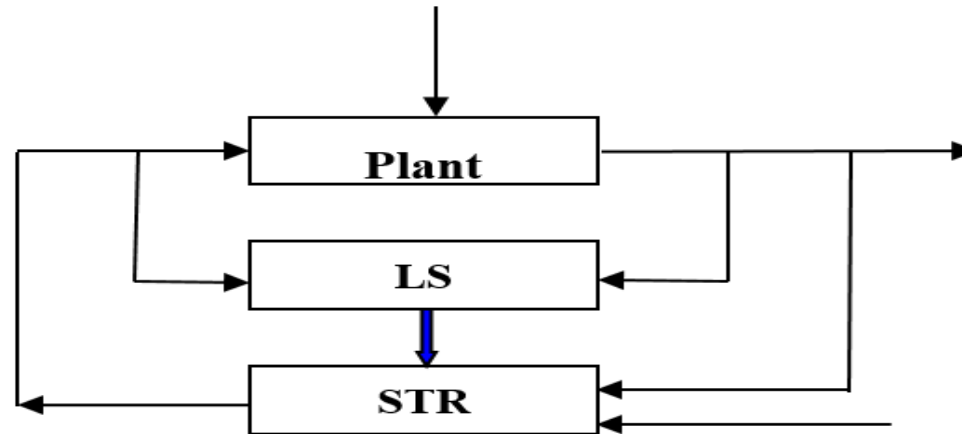

## Some Basic Problems

- Is the closed-loop system globally **stable**?
- Is the tracking error asymptotically **optimal**?
- Does the STR enjoy the best possible rate of **convergence**?



## Why the analysis is complicated?

- No statistical properties of the closed-loop system signals are available *a priori*, since they are characterized by a set of complicated nonlinear stochastic dynamical equations, which are nonstationary and strongly correlated.
- A key step is to establish the global stability, that depends on the LS. However, the verification of even the weakest possible convergence condition for LS (Lai-Wei, 1982) is still quite hard, without certain stability properties.

# Why the analysis is complicated?

- One needs to get out of circular arguments.

**Example**( $p = 1, q = 1$ ):

$$\begin{cases} y_{t+1} = ay_t + but + w_{t+1} \\ u_t = -\frac{1}{\hat{b}_t}(a_t y_t - y_{t+1}^*) \end{cases}$$
$$\begin{pmatrix} a_t \\ b_t \end{pmatrix} = \begin{pmatrix} \sum_{i=0}^{t-1} y_i^2 & \sum_{i=0}^{t-1} u_i y_i \\ \sum_{i=0}^{t-1} u_i y_i & \sum_{i=0}^{t-1} u_i^2 \end{pmatrix}^{-1} \begin{pmatrix} \sum_{i=0}^{t-1} y_i y_{i+1} \\ \sum_{i=0}^{t-1} u_i y_{i+1} \end{pmatrix}$$

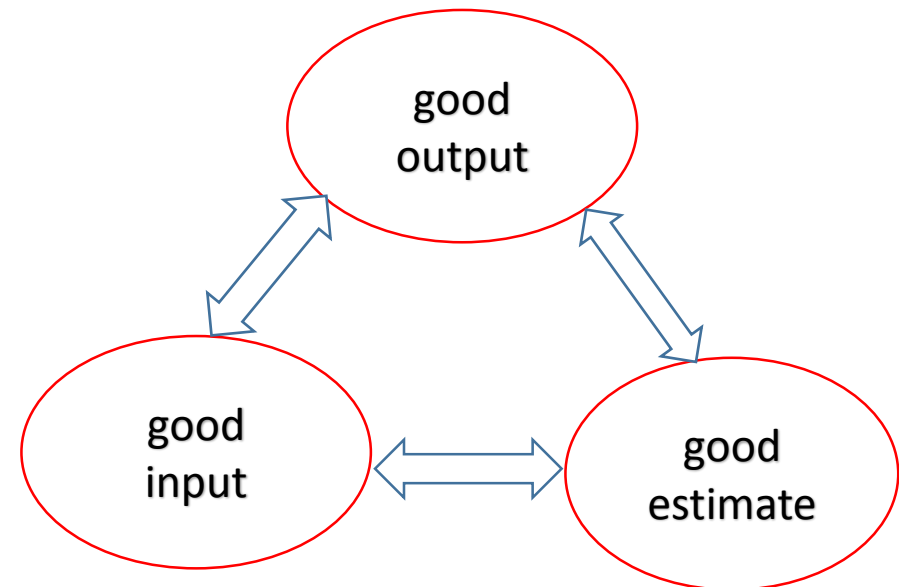

## Regret of Tracking

Note that the performance of adaptive tracking depends essentially on the quality of the adaptive predictor. The difference between the best prediction and the adaptive prediction (or tracking signal) may be referred to as the “**regret**” denoted by

$$R_k = (\mathbb{E}[y_{k+1}|\mathcal{F}_k] - \hat{y}_{k+1})^2,$$

which is usually not zero due to the existence of the unpredictable noises.

However, one may evaluate the **averaged regret** defined by

$$\frac{1}{n} \sum_{k=1}^n R_k.$$

It can be shown that stability and optimality will follow once the above averaged regret tends to zero as  $n$  increases to infinity.

## Theorem 1.1

Under Assumptions A1-A3, the averaged regret tends to zero. In other words, the closed-loop control system of STR is **globally stable**, i.e., for any initial condition,

$$\limsup_{n \rightarrow \infty} \frac{1}{n} \sum_{k=1}^n (y_k^2 + u_k^2) < \infty, \quad a.s.,$$

and **asymptotically optimal**, i.e.,

$$\limsup_{n \rightarrow \infty} \frac{1}{n} \sum_{k=1}^n (y_k - y_k^*)^2 = \min, \quad a.s..$$

## Theorem 1.2

Under some additional assumptions, the closed-loop control system will have the following **logarithm law** for the accumulated regret of tracking:

$$\lim_{n \rightarrow \infty} \frac{1}{\log n} \sum_{k=1}^n (\mathbb{E}[y_{k+1} | \mathcal{F}_k] - y_{k+1}^*)^2 = \dim(\theta) \sigma_w^2, \quad a.s.,$$

where  $\dim(\theta)$  is the dimension of the unknown parameter vector,  $\sigma_w^2$  is the conditional variance of the noises (assumed to be constant for simplicity).

**Remark:** The details of this theorem is given in [1], and a discussion why  $O(\log n)$  is the minimal order of magnitude that one may **at most expect** to achieve for the accumulated regret is found in [2].

[1] L. Guo, "Convergence and logarithm laws of self-tuning regulators", Automatica, Vol.31, No.3, pp.435-450, 1995.

[2] T.L. Lai, "Asymptotically efficient adaptive control in stochastic regression models", Adv. in Applied Math., 7, 23-45, 1986.

# Remarks

In the analysis of STR

- The convergence of the averaged regret of adaptive prediction is more relevant than the convergence of the LS itself. A detailed analysis of LS can provide a “sharp bound” for a certain accumulated weighted regret regardless of the input signal, which turns out to be critical for further analysis of the nonlinear closed-loop stochastic systems under STR.
- The [martingale theory](#) has played a fundamental role in dealing with non-stationary and correlated signals or data. This may continue to be so when we deal with more complicated data or signals that are generated from complex stochastic feedback systems, where independency and stationarity are not hold.

## Some Related Problems and Results

- **More on minimum phase linear stochastic systems**

MIMO with colored noises [1], and SISO with multiple delay and model reference[2].

- **Non-minimum phase linear stochastic systems**

The controllability of the estimated model is a key issue, which can be guaranteed (see [3]) by a random regularization approach combined with the self-convergence property established in [3] for the weighted LS proposed in [4]. An asymptotically optimal adaptive LQG control is given in [5].

[1] L.Guo and H.F.Chen, “The Åström-Wittenmark self-tuning regulator revisited and ELS-based adaptive trackers”, IEEE-TAC, 36(7), 1991.

[2] W. Ren and P.R. Kumar, “Stochastic adaptive prediction and model reference control”, IEEE-TAC, 39, 2047-2060, 1994.

[3] L. Guo, “Self-convergence of weighted Least-squares with applications to stochastic adaptive control”, IEEE-TAC, 41(1), 79-89, 1996.

[4] B. Bercu, “Weighted estimation and tracking for ARMAX models”, SICON, 33, 89-106, 1995.

[5] T. E. Duncan, L.Guo, B.Pasik-Duncan, “Adaptive continuous-time linear quadratic Gaussian control”, IEEE-TAC, 44(9), 1652-1662, 1999.

## Some Related Problems and Results

- **Jump Markov parameter linear stochastic systems**

A **necessary and sufficient** condition is given in [1] for adaptive stabilization in discrete-time, which is **different** from that for the non-adaptive case[2], and reveals an attenuation of feedback capability in the presence of jump parameter uncertainty.

There are also many investigations in continuous-time, see, e.g., [3] together with the references therein, and a complete characterization is yet to be found.

[1] X. Feng and L. Guo, “Necessary and sufficient conditions for adaptive stabilizability of jump linear systems”, *Communications in Information and Systems*, 1(2), 205-224, 2001.

[2] Y. Ji and H.J. Chizeck, “Jump linear quadratic Gaussian control: steady-state solution and testable conditions”, *Control Theory and Advanced Technology*, 6(3), 289-319,1990.

[3] P.E. Caines and J.F. Zhang, “On the adaptive control of jump parameter systems via nonlinear filtering”, *SIAM J. Control and Optimization*, 33(6), 1995.



## **2. PID Control**

# Problem Formulation

- Let  $x(t)$ ,  $v(t)$  and  $a(t)$  be the position, velocity and acceleration of a moving body in  $\mathbb{R}$  at time instant  $t$ .
- Assume that the external forces acting on the body consist of  $f$  and  $u$ , where  $f = f(x, v)$  is a nonlinear function of both the position  $x$  and velocity  $v$ , where  $u$  is the control force.
- The **Newton's second law** gives

$$ma(t) = f(x(t), v(t)) + u(t)$$

## State space equation

Denote  $x_1(t) = x(t)$  and  $x_2(t) = \frac{dx(t)}{dt} = \dot{x}(t)$ , then the state space equation of this basic mechanic system under PID control is

$$\begin{cases} \dot{x}_1 = x_2, \\ \dot{x}_2 = f(x_1, x_2) + u(t), \\ u(t) = k_p e(t) + k_i \int_0^t e(s) ds + k_d \frac{de(t)}{dt}, \end{cases} \quad (1)$$

where  $x_1(0), x_2(0) \in \mathbb{R}$  and  $e(t) = y^* - x_1(t)$ , and  $f(x_1, x_2)$  is an uncertain function.

# The Class of Uncertain Functions

$$\mathcal{F}_{L_1, L_2} = \left\{ f \in C^1(\mathbb{R}^2) \left| \frac{\partial f}{\partial x_1} \leq L_1, \left| \frac{\partial f}{\partial x_2} \right| \leq L_2, \forall x_1, x_2 \in \mathbb{R} \right. \right\}$$

where  $L_1$  and  $L_2$  are positive constants, and  $C^1(\mathbb{R}^2)$  denotes the space of all functions from  $\mathbb{R}^2$  to  $\mathbb{R}$  which are locally Lipschitz in  $(x_1, x_2)$  with continuous partial derivatives.

- $L_1$  and  $L_2$  correspond to the upper bounds of the “anti-stiffness” and the “anti-damping” coefficients of the nonlinear systems, respectively.

# The parameter manifold

Let us introduce the following 3-dimensional parameter manifold:

$$\Omega_{pid} = \left\{ \begin{bmatrix} k_p \\ k_i \\ k_d \end{bmatrix} \mid k_p > L_1, k_i > 0, (k_p - L_1)(k_d - L_2) > k_i + L_2 \sqrt{k_i(k_d + L_2)} \right\}$$

It is open and unbounded.

**An illustration:**

$$L_1 = 5 \text{ and } L_2 = 5, \\ 0 \leq k_p, k_i, k_d \leq 50.$$

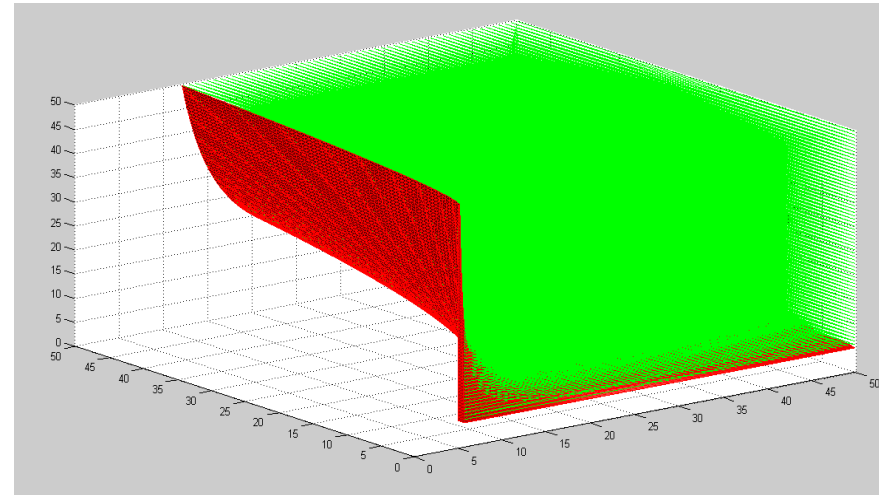

## Theorem 2.1

Consider the above PID controlled nonlinear uncertain system. Then, **whenever**  $(k_p, k_i, k_d) \in \Omega_{pid}$ , the above PID control system will satisfy

$$\lim_{t \rightarrow \infty} x_1(t) = y^*, \quad \lim_{t \rightarrow \infty} x_2(t) = 0,$$

exponentially fast, for any  $f \in \mathcal{F}_{L_1, L_2}$ , any initial state  $(x_1(0), x_2(0)) \in \mathbb{R}^2$  and any setpoint  $y^* \in \mathbb{R}$ .

**Remark.** The above theorem was proven in [1]. Extensions to high-dimensional uncertain nonlinear systems can be found in [2].

[1] C.Zhao and L.Guo, "PID controller design for second order nonlinear uncertain systems", Sci. China Inf. Sci., 60(2): 022201, 2017.

[2] J.K.Zhang and L. Guo, "Theory and Design of PID Controller for Nonlinear Uncertain Systems", IEEE Contr. Syst. Lett., 3(3), 643 - 648, 2019.

## Remark

Theorem 2.1 is a **global** result. It demonstrates that PID controller has **large-scale and two-sided robustness** in the following sense:

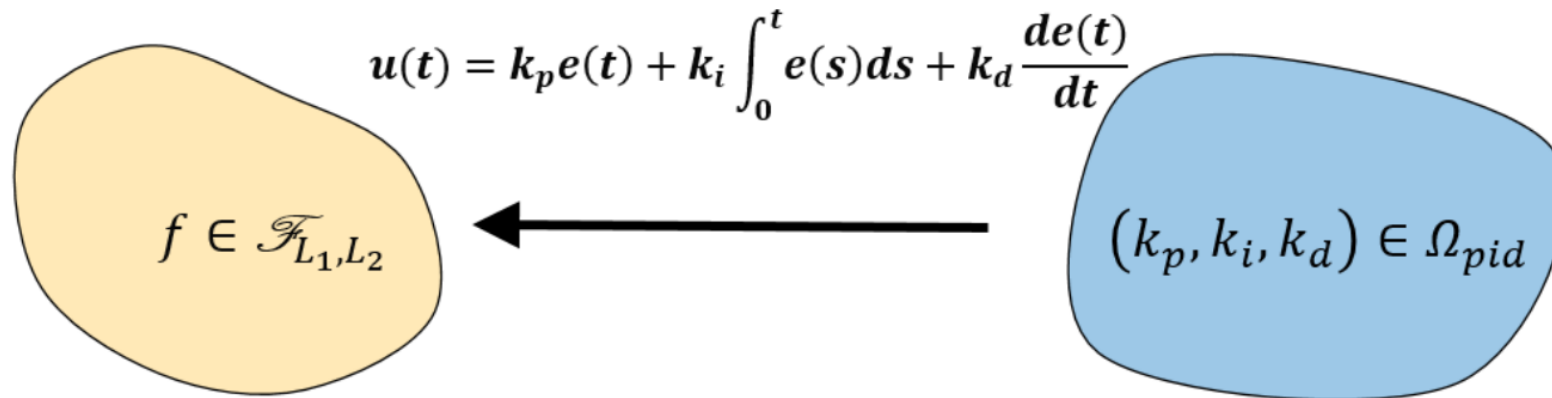

- Actually, the selection of the PID parameters has **much flexibility**. More performance requirements including the transient may be further studied by optimizing the PID parameters from the manifold  $\Omega_{pid}$ .
  
- A natural question:

Is  $\Omega_{pid}$  necessary?



## Case I: an affine situation

Let us consider

$$\mathcal{G}_{L_1, L_2} = \left\{ f \in C^2(\mathbb{R}^2) \left| \frac{\partial f}{\partial x_1} \leq L_1, \frac{\partial f}{\partial x_2} \leq L_2, \frac{\partial^2 f}{\partial x_2^2} = 0, \forall x_1, x_2 \in \mathbb{R} \right. \right\},$$

where  $L_1 > 0$ ,  $L_2 > 0$  are constants and  $C^2(\mathbb{R}^2)$  is the space of twice continuously differentiable functions from  $\mathbb{R}^2$  to  $\mathbb{R}$ .

## Theorem 2.2

For any  $f \in \mathcal{G}_{L_1, L_2}$ , any initial conditions and any setpoint  $y^* \in \mathbb{R}$ , the control system satisfies

$$\lim_{t \rightarrow \infty} x_1(t) = y^*, \quad \lim_{t \rightarrow \infty} x_2(t) = 0,$$

**if and only if** the PID parameters  $(k_p, k_i, k_d)$  belongs to the following 3-dimensional manifold:

$$\Omega'_{pid} = \left\{ \begin{bmatrix} k_p \\ k_i \\ k_d \end{bmatrix} \mid k_p > L_1, k_i > 0, (k_p - L_1)(k_d - L_2) > k_i \right\}.$$

## Remark: The capability of PID

Given a PID controller with parameter  $(k_p, k_i, k_d)$  ( $k_i > 0$ ), **what is the largest possible class of nonlinear uncertain functions it can deal with?**

Note that the “size” of  $\mathcal{G}_{L_1, L_2}$  can be “measured” by  $L_1, L_2$ . The boundary of

$$\{(L_1, L_2) \in \mathbb{R}^2 \mid L_1 < k_p, L_2 < k_d - k_i(k_p - L_1)^{-1}\}$$

may reflect the maximum capability.

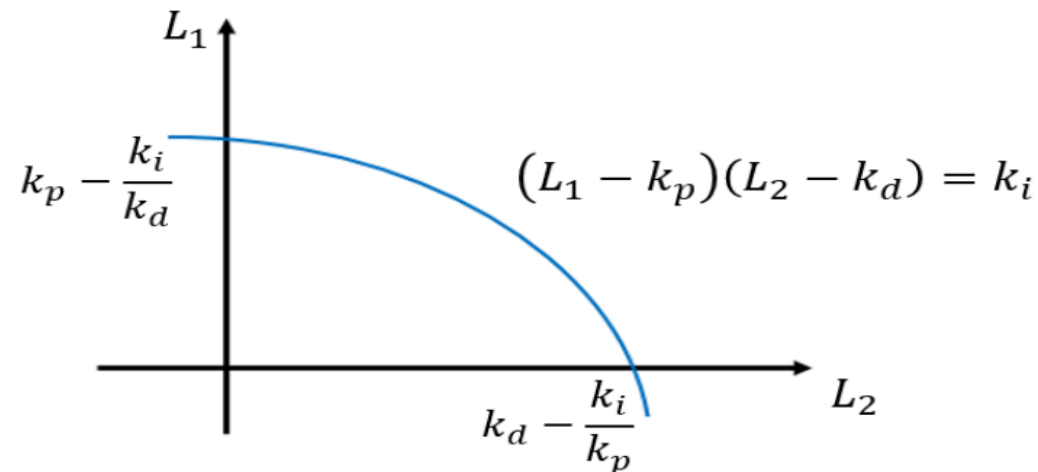

## Case II: equilibrium case

When  $(y^*, 0)$  is an equilibrium point of the open-loop systems, i.e.  $f(y^*, 0) = 0$ , the I-term is not necessary for regulation.

Define a functional class

$$\mathcal{F}_{L_1, L_2, y^*} = \left\{ f \in C^1(\mathbb{R}^2) \left| \frac{\partial f}{\partial x_1} \leq L_1, \frac{\partial f}{\partial x_2} \leq L_2, \forall x_1, x_2, f(y^*, 0) = 0 \right. \right\}$$

## Theroem 2.3

$$\begin{cases} \dot{x}_1 = x_2 \\ \dot{x}_2 = f(x_1, x_2) + u(t) \\ u(t) = k_p e(t) + k_d \dot{e}(t) \end{cases}$$

where the unknown  $f \in F_{L_1, L_2, y^*}$ . Then for any  $f \in F_{L_1, L_2, y^*}$ , we have

$$\lim_{t \rightarrow \infty} x_1(t) = y^*, \quad \lim_{t \rightarrow \infty} x_2(t) = 0$$

**if and only if** the PD parameters  $(k_p, k_d)$  lie in the following 2-dimensional manifold:

$$\Omega_{pd} = \{(k_p, k_d) \mid k_p > L_1, k_d > L_2\}.$$

**Remark.** The proof follows the [Markus-Yamabe theorem](#), which had been a conjecture in ODE and proven to be true for nonlinear systems in the plane.

# A further formula for PID parameters

One way to further specify the PID parameters from  $\Omega_{pid}$  is given by [1]:

$$\begin{cases} k_p = k_{ap} + \omega_0 k_{ad} \\ k_i = \omega_0 k_{ap} \\ k_d = k_{ad} + \omega_0 \end{cases}$$

where  $\omega_0$  can be any positive constant above a lower bound explicitly given in [1], and where  $(k_{ap}, k_{ad})$  is a given pair of real numbers such that the following second order polynomial has zeros in the left-half plane:

$$s^2 + k_{ad}s + k_{ap} = 0.$$

# A Reparameterization

$$u(t) = k_{ap}e(t) + k_{ad}\dot{e}(t) - \hat{f}_t + \ddot{r}(t),$$

where  $e(t) = r(t) - x_1(t)$ ,  $r(t)$  is a designed transient process, and

$$\hat{f}_t = -\omega_0 \left\{ k_{ad}e(t) + k_{ap} \int_0^t e(s)ds + \dot{e}(t) \right\}$$

can serve as an online estimator for the uncertain dynamics  $f$ .

**Remark.** The above formula stems from the inherent connection between the PID and the ADRC (Active disturbance rejection control) proposed by J.Q. Han in [1](see also [2]), where a key ingredient is an extended state observer (ESO) used for estimating the uncertain dynamics. The ESO may be designed as a linear one[3], and the reduced order linear ESO[4] will give the above estimator for the unknown  $f$ .

[1] J. Q. Han, “Auto-disturbance rejection control and its applications”, *Control and Decision*, 13(1), 1998 (in Chinese).

[2] J. Q. Han, “From PID to active disturbance rejection control”, *IEEE Trans. on Industrial Electronics*, 56, 900–906, 2009.

[3] Z. Gao, “Scaling and bandwidth-parameterization based controller tuning”, *Proc. Amer. Control Conf.*, 6, 2006.

[4] Y. Huang, W. Xue, “Active disturbance rejection control: methodology and theoretical analysis”, *ISA trans.*, 53(4), 963-976, 2014.

# An illustration

$$\begin{cases} \dot{x}_1 = x_2 \\ \dot{x}_2 = a \sin x_1 + bx_2 + u \end{cases}$$

where  $|a| \leq 1, |b| \leq 1$ , unknown,  $x_1(0) = 3, x_2(0) = 2$ . Let  $y^* = 1$ .  
Set  $k_{ap} = 1, k_{ad} = 2, \omega_0 = 7$ .

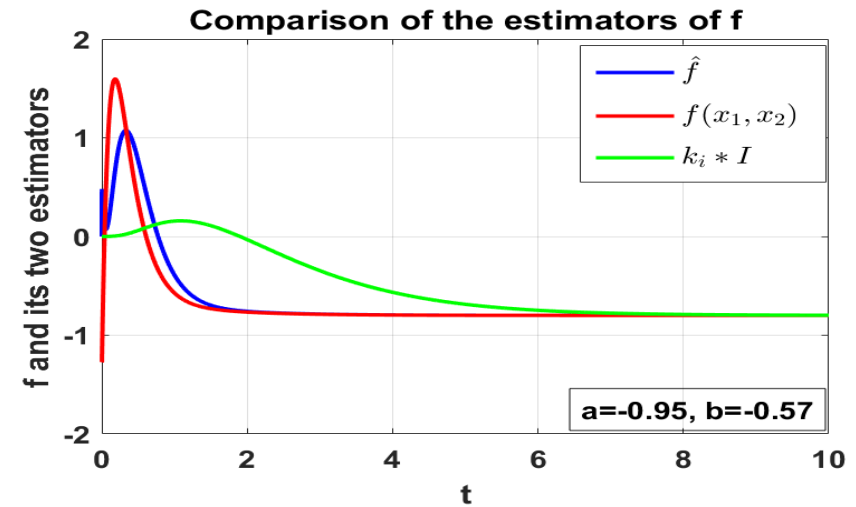
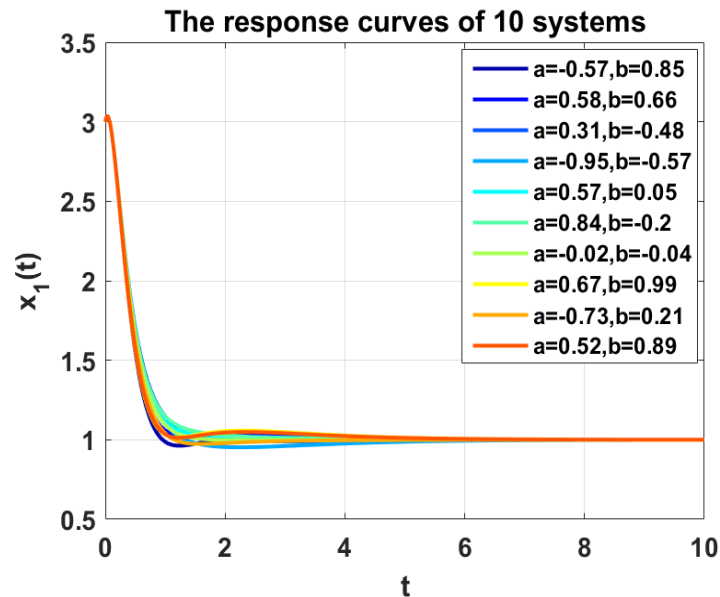

$$\hat{f} = -\omega_0 \left\{ k_{ad} e(t) + k_{ap} \int_0^t e(s) ds + \dot{e}(t) \right\}$$



# An Extension

Consider the SISO system,

$$\begin{cases} \dot{x} = f(x) + g(x)u, & x \in \mathbb{R}^n \\ y = h(x), \end{cases}$$

where  $f : \mathbb{R}^n \rightarrow \mathbb{R}^n$ ,  $g : \mathbb{R}^n \rightarrow \mathbb{R}^n$  and  $h : \mathbb{R}^n \rightarrow \mathbb{R}$  are sufficiently smooth **unknown** functions.

Extended PID Controller:

$$u(t) = k_1 e(t) + k_0 \int_0^t e(s) ds + k_2 \dot{e}(t) + \cdots + k_n e^{(n-1)}(t)$$

**Remark.** General structure with relative degree  $n$ . Globally defined with global or semi-global stabilizability. Large scale and two-sided robustness. Differential trackers may be used.

## Remarks

Some related problems on MIMO, stochastic, and multi-agent nonlinear uncertain systems may also be investigated. It would be interesting to further consider

- Situations such as saturation, dead-zone, time-delay, sampled data and observation noises;
- Other extensions of the classical PID to e.g., adaptive and nonlinear PID, for more general uncertain nonlinear systems;
- Making more efforts in combining classical ideas with modern methods.

# **3. Feedback Capability**

# A Theoretical Framework

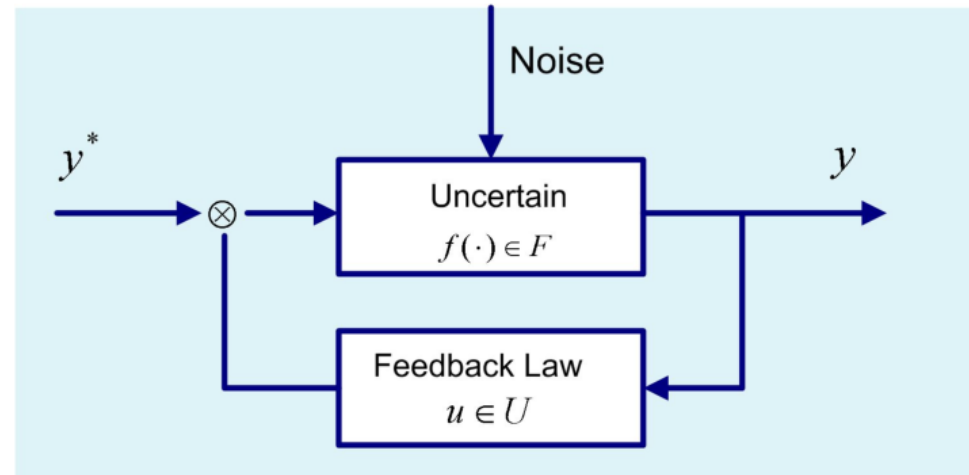

$$\sup_F \left\{ \text{size}(F) : \inf_{u \in U} \sup_{f \in F} \sup_{t \geq 0} |y_t(f, u)| < \infty, \forall y_0 \in \mathbb{R} \right\}$$

# System Information

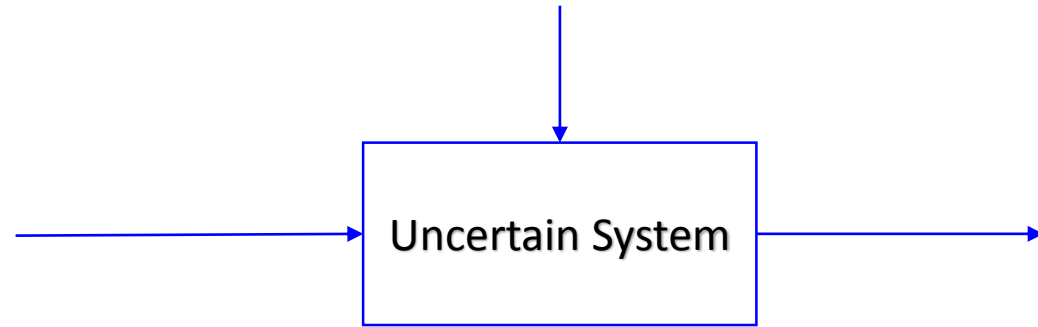

$$\begin{aligned}\text{Information} &= \text{prior} + \text{posterior} \\ &= I_0 + I_t\end{aligned}$$

$I_0$  = prior knowledge about the uncertain system

$I_t$  = posterior knowledge about the uncertain system

=  $\{y_1, y_2, \dots, y_t\}$  (Observations/Data)

# Feedback Mechanism

- **Feedback signal  $u_t$**  : there is a measurable mapping

$$f_t : \mathbb{R}^{t+1} \rightarrow \mathbb{R}^1$$

such that

$$u_t = f_t(y_0, y_1, \dots, y_t)$$

- **Feedback law  $u$**  :

$$u = \{u_t, \quad t \geq 0\}$$

- **Feedback mechanism  $U$** :

$$U = \{u \mid u \text{ is any feedback law}\}$$

## The Critical Value $b = 4$

$$y_{t+1} = f(\theta, y_t) + u_t + w_{t+1}.$$

Let the **sensitivity function** satisfy

$$\frac{\partial f(\theta, x)}{\partial \theta} = \Theta(|x|^b), \quad x \rightarrow \infty, \quad b \geq 0,$$

where  $\theta \in \mathbb{R}^1$  is unknown and  $\{w_t\}$  is a white noise or bounded disturbance.

**Theorem ( $b = 4$  is critical):**

The above class of systems is globally stabilizable by feedback mechanism **if and only if  $b < 4$ .**

**Remark.** This theorem was first found and proven for the case  $f(\theta, y_t) = \theta f(y_t)$  in [1], with the present case given in [2].

[1] L. Guo, "On critical stability of discrete-time adaptive nonlinear control", IEEE-TAC, 42(11), 1488-1499, 1997.

[2] C. Li and L. Guo, "On feedback capability in nonlinearly parameterized uncertain dynamical systems" IEEE-TAC, 56(12), 2946-2951, 2011.

## A Polynomial Criterion

Multiple parameter case

$$y_{t+1} = \theta^\tau f(y_t) + u_t + w_{t+1}$$

- $\theta \in \Theta \triangleq \{\theta \in \mathbb{R}^p : \|\theta\| \leq R\}$  is an unknown vector;
- $\{w_t\}$  is either bounded or Gaussian white noise;
- $f(y_t) \triangleq [f_1(y_t), \dots, f_p(y_t)]^\tau$  belongs to:

$$\mathcal{F}(b) = \{f(\cdot) : f_i(x) = \Theta(|x|^{b_i}), \text{ as } x \rightarrow \infty\}$$

where  $b = (b_1 \cdots b_p)$ , with  $b_1 > b_2 > \cdots > b_p > 0$ , and  $b_1 > 1$ .



Define a characteristic polynomial using  $b_i$ :

$$P(z) = z^{p+1} - b_1 z^p + (b_1 - b_2) z^{p-1} + \cdots + (b_{p-1} - b_p) z + b_p$$

**Theorem** Let  $f \in \mathcal{F}(b)$  be a nonlinear function. Then the above uncertain nonlinear dynamical system with  $\theta \in \Theta$  is globally stabilizable by the feedback mechanism **if and only if**

$$P(z) > 0, \quad \forall z \in (1, b_1)$$

**Remark.** The polynomial  $P(z)$  was introduced in [1] with a necessity proof, the complete proof was given in [2] and [3] for deterministic and stochastic systems respectively.

- [1] L.L. Xie and L. Guo, "Fundamental limitations of discrete-time adaptive nonlinear control", IEEE-TAC, 44(9), 1999
- [2] C.Li, L.L. Xie and L.Guo, "A polynomial criterion for adaptive stabilization of discrete-time nonlinear systems", Commu. & Inform. Syst., 6(4), 273-298, 2006.
- [3] C. Li and J. Lam, "Stabilization of discrete-time nonlinear uncertain systems by feedback based on LS algorithm" SICON, 51(2), 1128–1151, 2013.

## Rationale behind Limitations

- **Stochastic embedding** can give

$$E[y_{t+1}^2 | \mathcal{F}_t^y] = E[(f(\theta, \phi_t) - \hat{f}(\theta, \phi_t))^2 | \mathcal{F}_t^y] + \hat{f}^2(\theta, \phi_t) + \sigma_w^2.$$

where  $\hat{f}(\theta, \phi_t)$  is the best mean square prediction.

- **Conditional Cramér-Rao-like inequality** for dynamical systems will provide a lower bound to the prediction error for any feedback control, expressed by the Fisher information matrix and the sensitivity function.
- **Analysis of the nonlinear dynamics** will then lead to a connection to the polynomial criterion.

# The Critical Value $\frac{3}{2} + \sqrt{2}$

**Nonparametric** control system

$$y_{t+1} = f(y_t) + u_t + w_{t+1}, \quad y_0 \in \mathbb{R}^1$$

with unknown function  $f(\cdot) \in \mathcal{F} = \{\text{all } \mathbb{R}^1 \rightarrow \mathbb{R}^1 \text{ mappings}\}$ .

The Lipschitz norm on  $\mathcal{F}$ :

$$\|f\| = \sup_{x \neq y} \frac{|f(x) - f(y)|}{|x - y|}$$

The set of uncertain functions:

$$\mathcal{F}(L) = \{f \in \mathcal{F} : \|f\| \leq L\}$$

**$L$ : Serves as a measure of uncertainty**

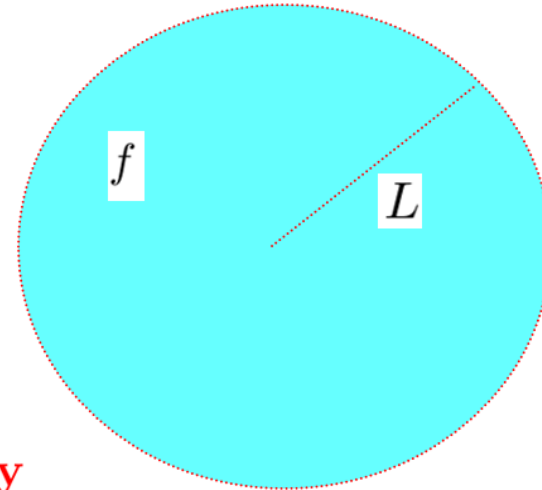

**Theorem.** The above class of uncertain dynamical systems described by  $\mathcal{F}(L)$  is globally stabilizable by the feedback mechanism **if and only if**

$$L < \frac{3}{2} + \sqrt{2}$$

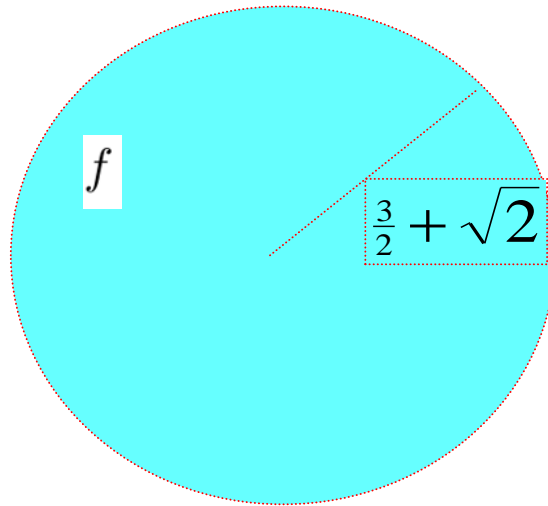

$$\mathcal{F}(L) = \{f \in \mathcal{F} : \|f\| \leq L\}$$

# A General Theorem

Semi-parametric model:

$$y_{t+1} = g(\theta, \phi_t) + f(y_t) + w_{t+1}, \quad t \geq 0,$$

where the uncertainties  $\theta \in \Theta \subset R^m$ ,  $f \in \mathcal{F}(L)$ ,  $w$  is bounded, and  $\phi_t = [y_t, y_{t-1}, \dots, y_{t-p+1}, u_t, u_{t-1}, \dots, u_{t-q+1}]^\tau$ . Assume that the system is “minimum phase” and that the sensitivity function of  $g(\cdot, \cdot)$  is bounded by a linear growth, etc.

**Theorem.** The above uncertain dynamical system with  $\{(\theta, f) \in (\Theta, \mathcal{F}(L))\}$  is globally stabilizable by the feedback mechanism **if and only if**

$$L < \frac{3}{2} + \sqrt{2}$$

## Remarks

- **Modeling and feedback are two main techniques in dealing with uncertainties, and the above theorem quantitatively shows how modeling and feedback could be complementary in control systems design.**
- **Further results may be found for both parametric case (e.g., [1],[2]) and nonparametric case (e.g., [3],[4]). Fundamental limitations on the sampled-data feedback mechanism are investigated in [5] followed by a refinement in [6].**

[1] C. Li and L. Guo, "On feedback capability in nonlinearly parameterized uncertain dynamical systems", IEEE-TAC, 56(12), 2946-2951, 2011.

[2] Z. Liu and C. Li, "Is it possible to stabilize discrete-time parameterized uncertain systems growing exponentially fast?" ,SICON, 57(3), 1965–1984, 2019.

[3] B. Li and G. Shi, "Maximum Capability of Feedback Control for Network Systems", Proc. 37th Chinese Control Conference, 6547-6554, 2018

[4] V.F. Sokolov, "Adaptive stabilization of parameter-affine minimum-phase plants under Lipschitz uncertainty", Automatica, 73, 64-70, 2016.

[5] F. Xue and L. Guo, "On limitations of the sampled-data feedback for nonparametric dynamical systems", J. Systems Science and Complexity, 15(3), 225-250, 2002.

[6] J.L.Ren, Z.B.Cheng and L.Guo, "Further results on limitations of sampled-data feedback", J. Systems Science and Complexity, 7:817-835, 2014.

## Remarks

- All the impossibility theorems presented in this part enjoy **universality** in the sense that they are actually valid for any larger class of uncertain systems and for any feedback law.
- The main results indicate that the feedback capability depends on both **information uncertainty** and **structural complexity**, and that adaptive prediction (estimation) and “sensitivity” functions play a crucial role.
- There appears to be **fundamental differences** between continuous-time and sampled-data (or discrete-time) feedbacks for uncertain nonlinear systems, when the sampling rate is prescribed.

# Concluding Remarks

- This lecture has presented some basic results on feedback and uncertainty for three basic problems, i.e., STR, PID and feedback capability. There are many more problems remain to be solved or investigated.
- The rapid development of information technology makes it possible to investigate more and more complex control systems, and at the same time brings a series of interesting new problems, whose investigation may still depend on our understanding of the basic concepts and problems in the field.



# Concluding Remarks(cont'd)

- Mathematical models play a basic role in control theory even if they may have large uncertainties. However, if the models are not regarded as approximations of the real-world systems and, instead, just taken as an intermediate step in controller design, then great efforts are still needed towards a comprehensive understanding of the boundaries of practical applicability of the controller.
- Furthermore, besides uncertainties, many systems to be controlled or regulated in social, economic, biological and the future “intelligent” engineering systems, may have their own objectives to pursue. Such complex uncertain systems, may not belong to the traditional framework of control or game theory, and call for more research attention[1].

# Acknowledgements

- **Collaborators**

H.F.Chen, J.F.Zhang, Y.Huang, W.C.Xue,

L.L.Xie, F.Xue, M.Y.Huang, C.Y.Li, Y.X.Zhang, C.D.Huang,

J.L.Ren, R.R.Zhang, C.Zhao, S.Yuan, J.K.Zhang, S.Zhong .....

- **Colleagues**

China, USA, Australia, Sweden, Canada, France, Italy, Japan, Russian, .....

- **Funding agencies**

NSFC, CAS, MSTC, .....

**Thank You !**